Richard

SOFAS

2016

Antonio Citterio



Description

Richard ist ein neues Stuhlsystem mit harmonischem, modernem Design, das sich an klassische Vorbilder anlehnt und das Thema der Modularität aufgreift, mit 76 Elementen, die in zwei Tiefen erhältlich sind: cm 93 für formale und platzsparende Lösungen, cm 123 für großzügigere, informelle Kombinationen. Die flexiblen Gestaltungsmöglichkeiten und das einfache Verbindungssystem bieten viel Freiraum für unterschiedlichste Konfigurationen von einer traditionellen bis hin zu einer kommunikativen Anordnung mit Sitzelementen, Bänken, Hockern und Chaise Longue. Dank der breiten Auswahl an Stoffbezügen in Kombination mit Profilen in ähnlichen oder Kontrastfarben, ebenso wie an Lederbezügen mit Profilen aus demselben Leder kann jedem Modell eine starke persönliche Note mit ein- oder kontrastfarbigen Lösungen verliehen werden. Der Unterbau des Gestells wird durch ein Metallprofil in den Ausführungen schwarz verchromt lackiert oder hartzinnfarben lackiert hervorgehoben. Optionale Kissen in vier verschiedenen Größen (cm 65x50, 48x48, 55x30, 38x38) sorgen für zusätzlichen Komfort

Technical information

Innenrahmen

Stahlrohre und -profile

Innenrahmen Füllung

kalt elastischer Polyurethanschaum Bayfit®, Polyesterfaser

Sitzkissen Füllung

geformtes Polyurethan verschiedener Dichten, visco-elastischer Polyurethan, sterilisierte Daunen, Polyesterfaser

Rückenkissen Füllung

Polyesterfaser, geformtes Polyurethan, sterilisierte Daunen

Untere Kante

Aluminiumguss und fließgepresstes Aluminium

Gleiter

Material thermoplastisch

Bezug

Stoff (Profile aus Stoff Bellano oder Bormio) oder Leder

Technical drawings

9RA230

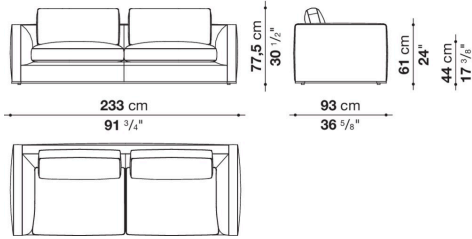

9RA260

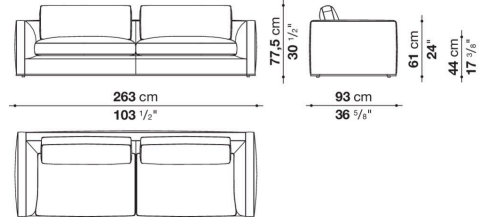

9RA280

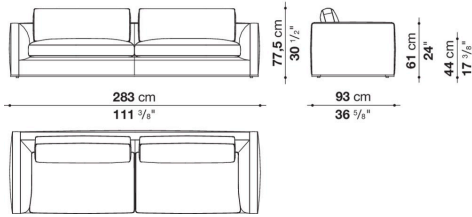

9RA85C

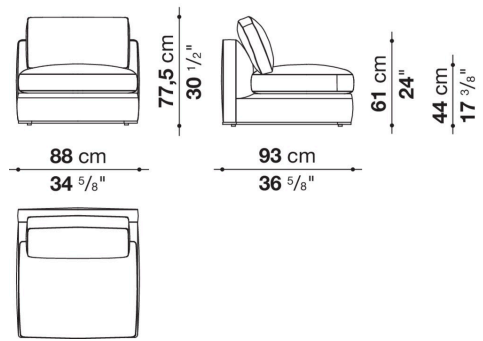

9RA100C

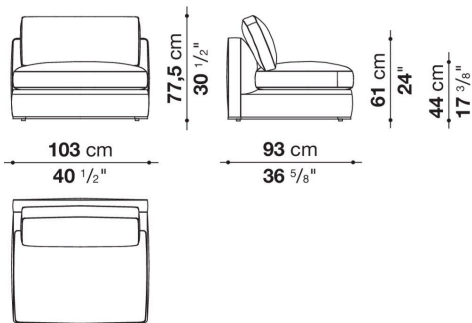

9RA190C

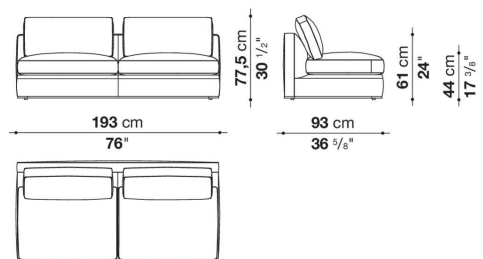

9RA220C

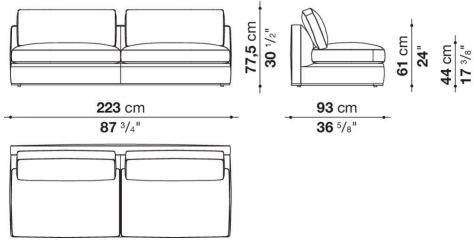

9RA240C

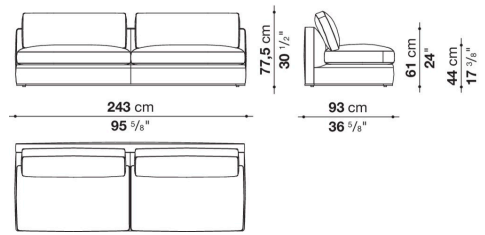

9RA105TS

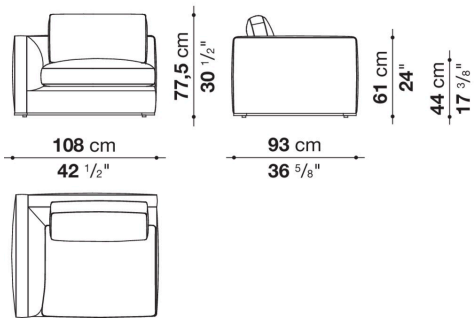

9RA105TD

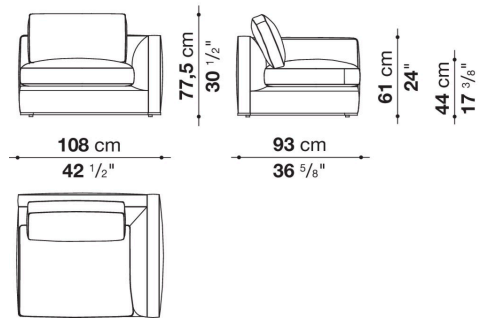

9RA120TS

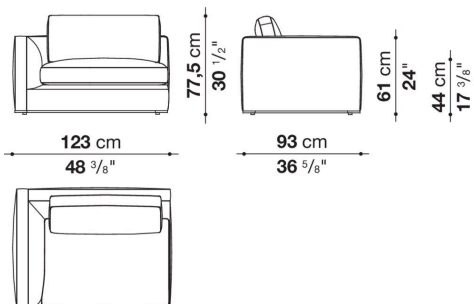

9RA120TD

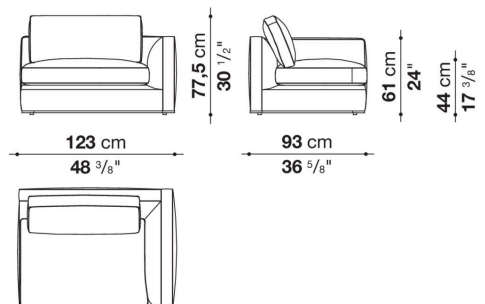

9RA210TS

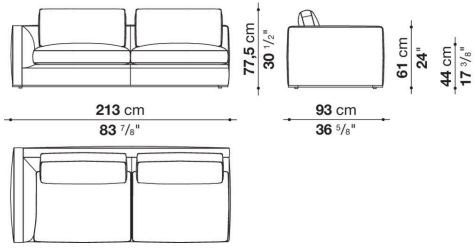

9RA210TD

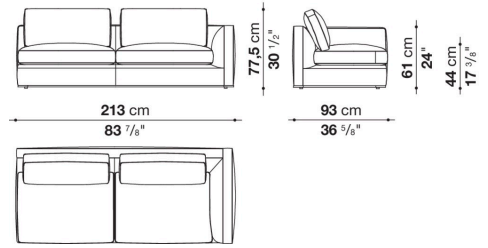

9RA240TS

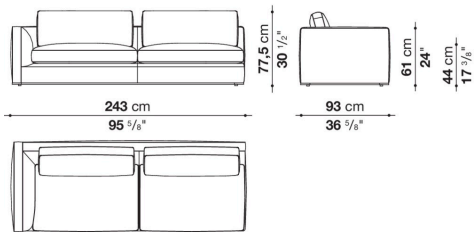

9RA240TD

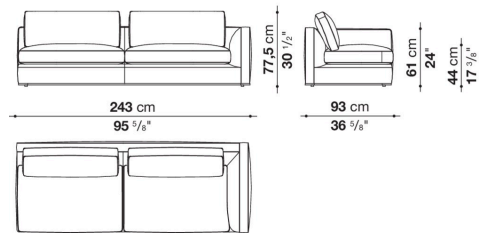

9RA260TS

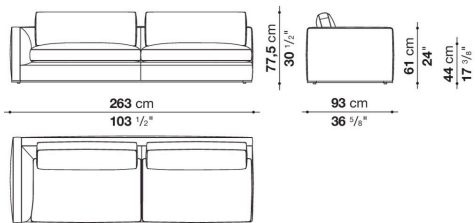

9RA260TD

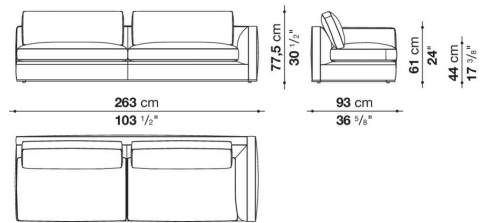

9RA190PS

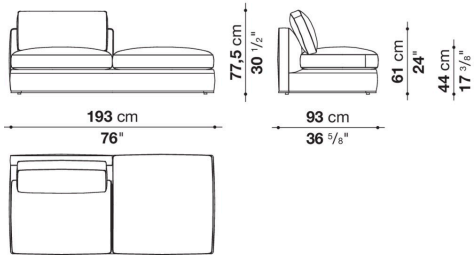

9RA190PD

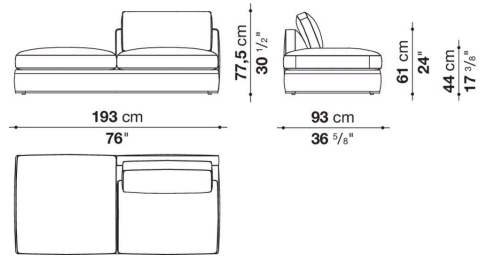

9RA220PS

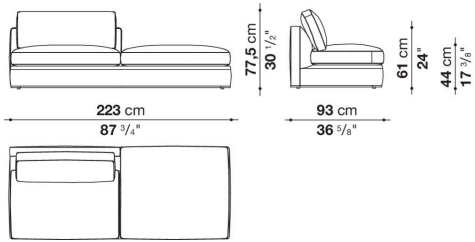

9RA220PD

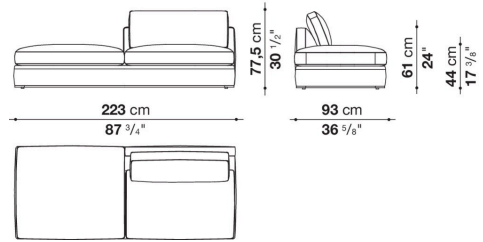

9RA240PS

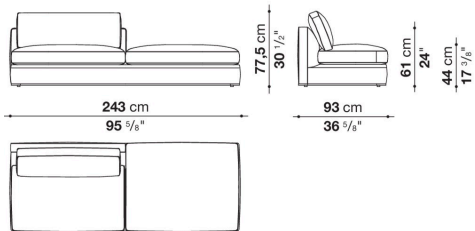

9RA240PD

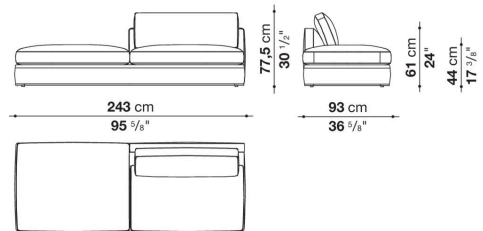

9RA210TPS

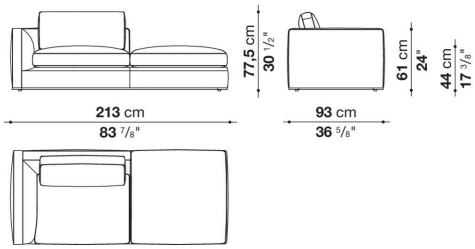

9RA210TPD

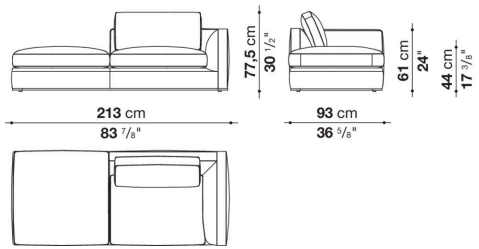

9RA240TPS

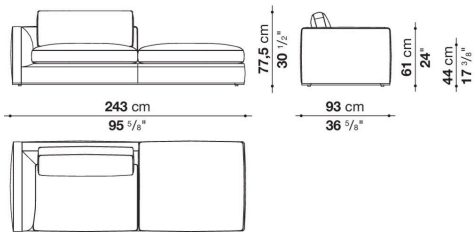

9RA240TPD

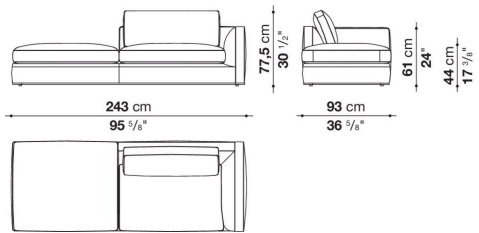

9RA260TPS

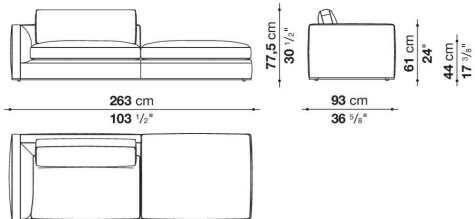

9RA260TPD

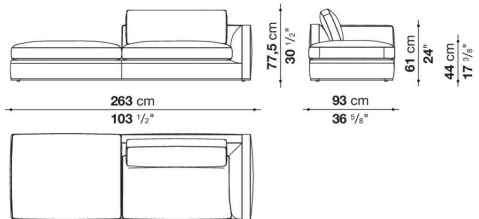

9RA210LS

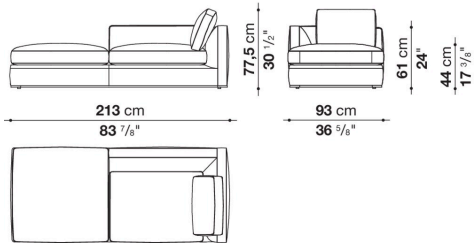

9RA210LD

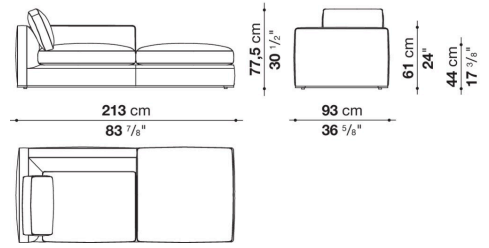

9RA240LS

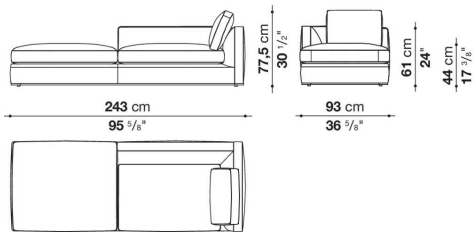

9RA240LD

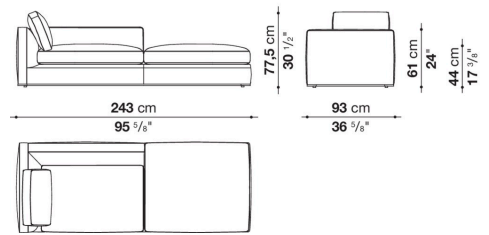

9RA260LS

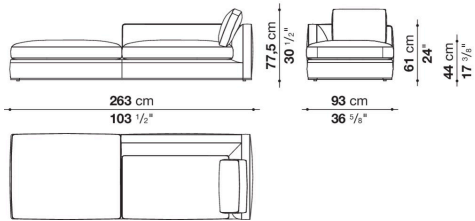

9RA260LD

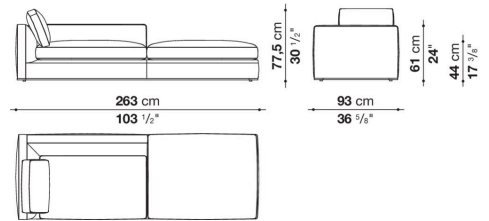

9RA85P

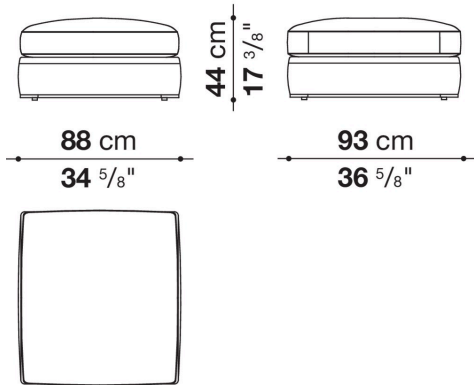

9RA100P

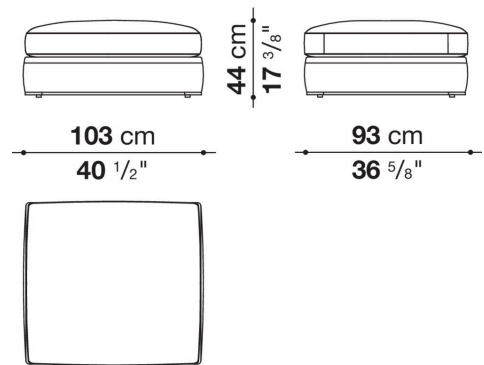

9RA190P

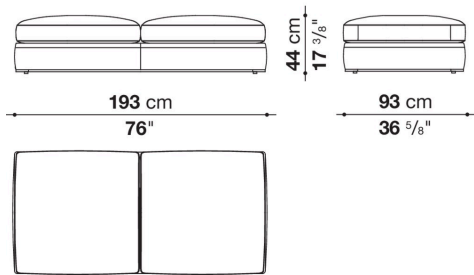

9RA220P

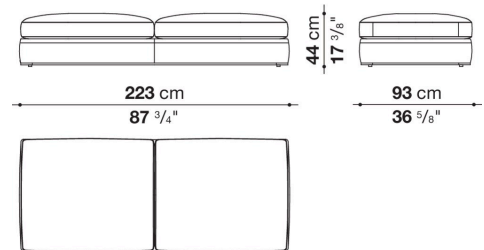

9RA240P

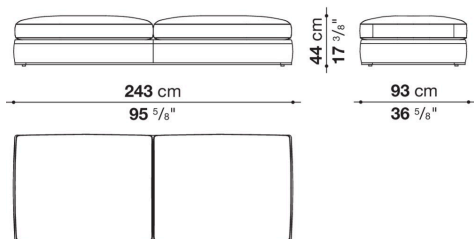

RA90TS

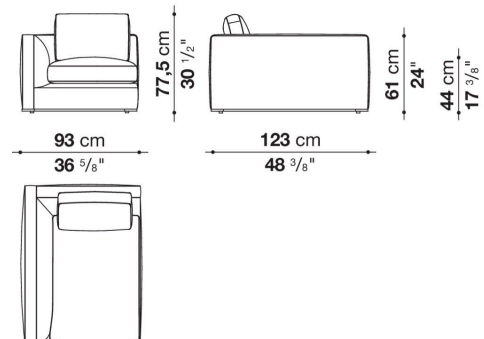

RA90TD

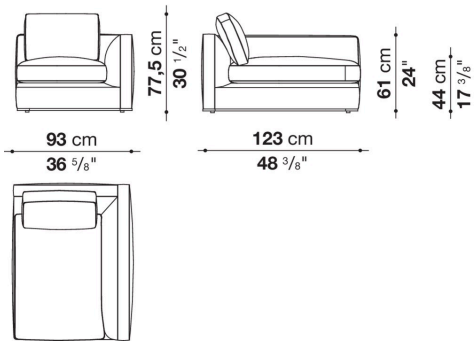

RA85C

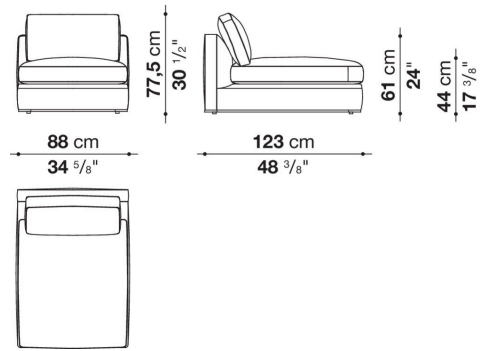

RA260TS

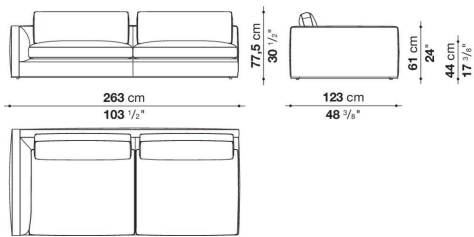

RA260TPS

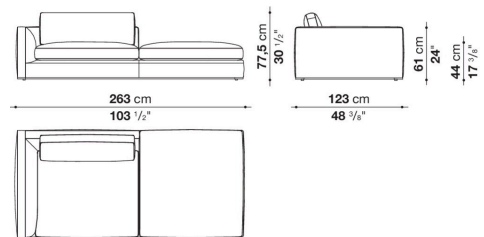

RA260TPD

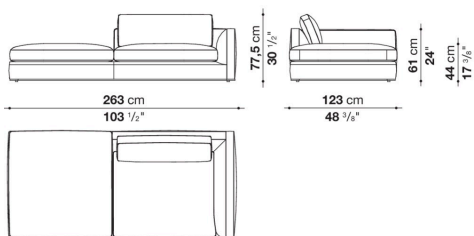

RA260LS

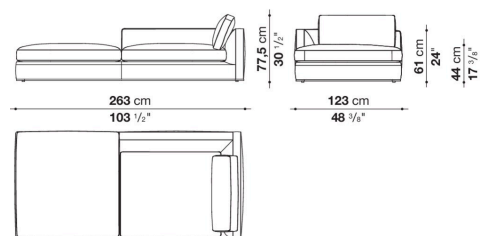

RA260LD

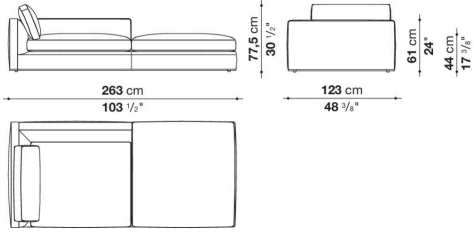

RA260TD

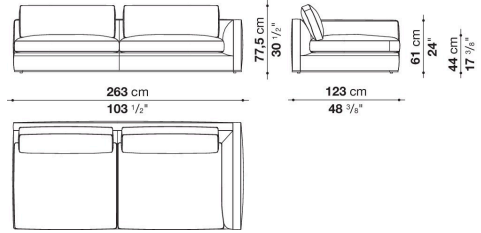

RA240TS

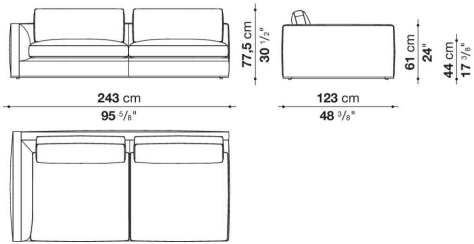

RA240TPS

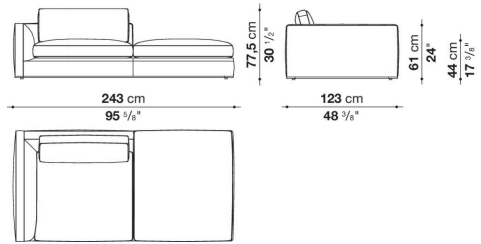

RA240TPD

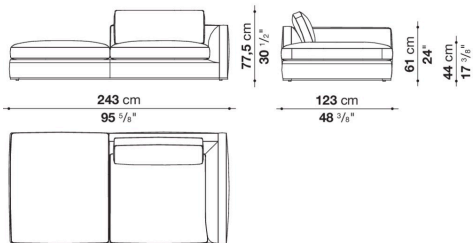

RA240TD

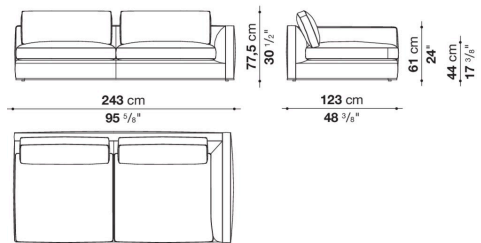

RA240PS

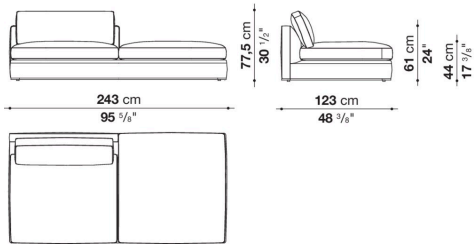

RA240PD

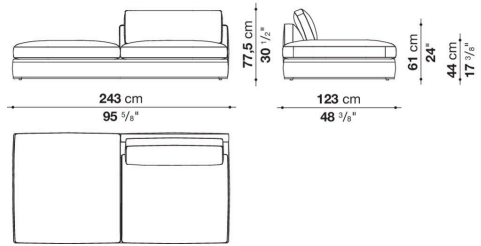

RA240LS

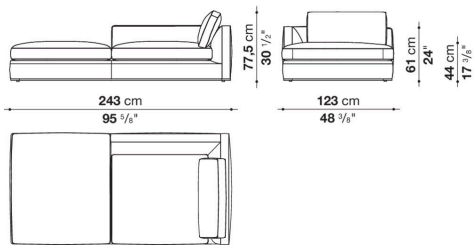

RA240LD

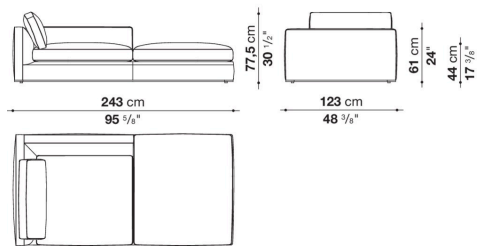

RA240C

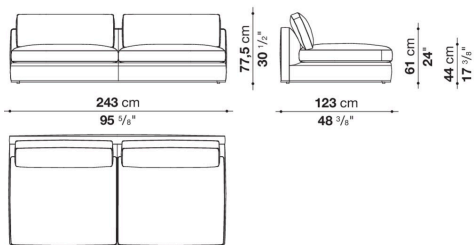

RA220PS

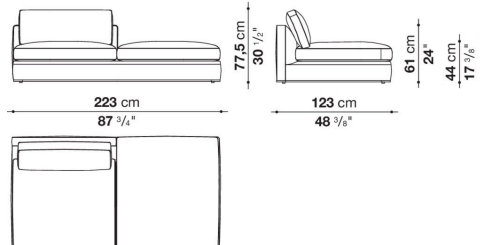

RA220PD

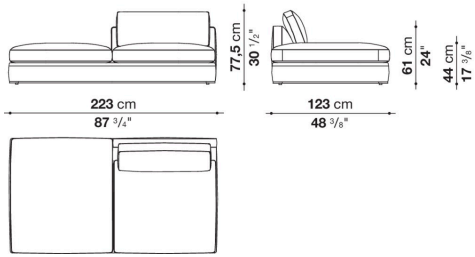

RA220C

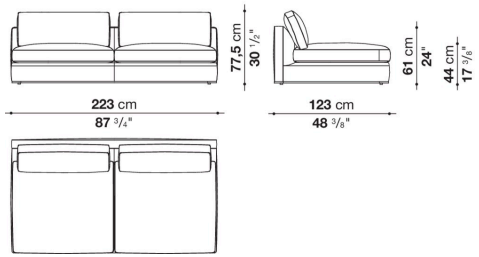

RA210TS

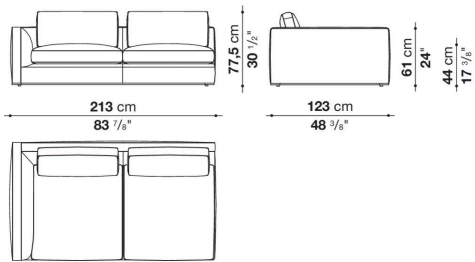

RA210TPS

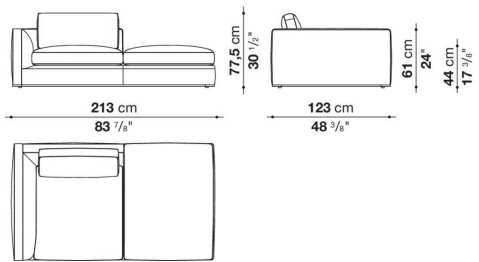

RA210TPD

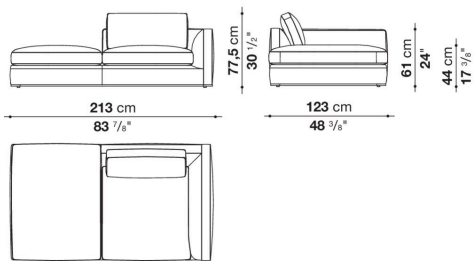

RA210TD

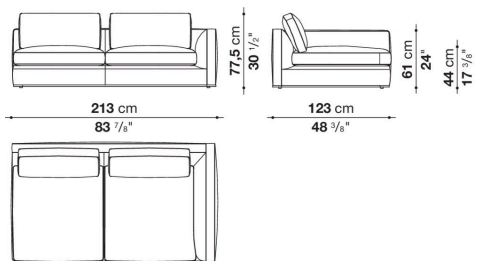

RA210LD

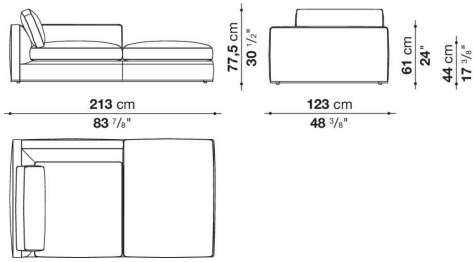

RA190PS

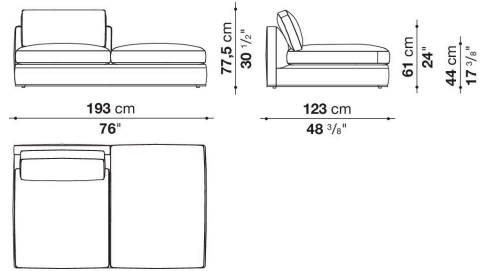

RA210LS

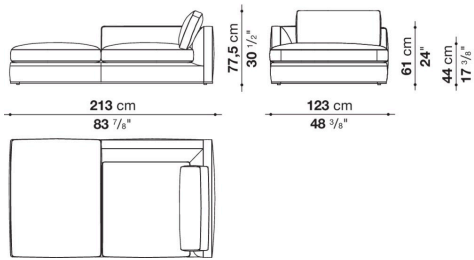

RA190PD

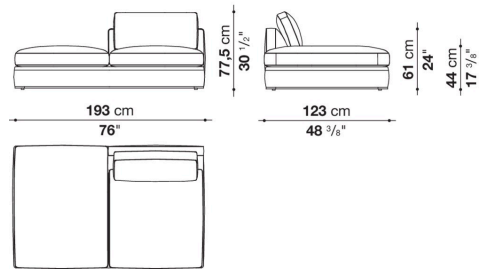

RA190C

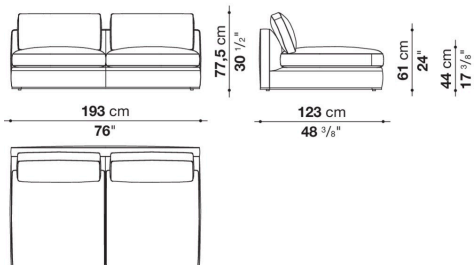

RA120TS

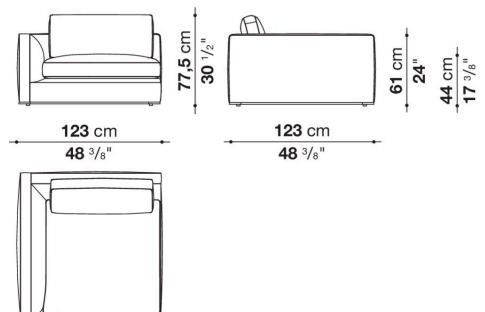

RA120TD

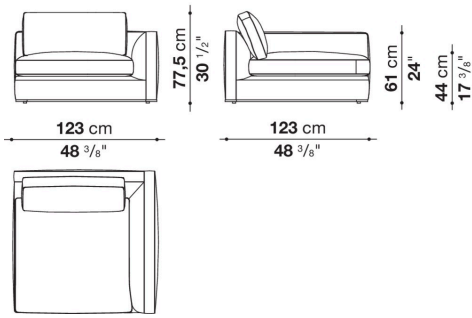

RA105TS

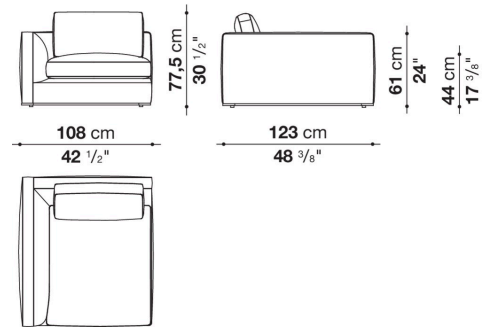

RA105TD

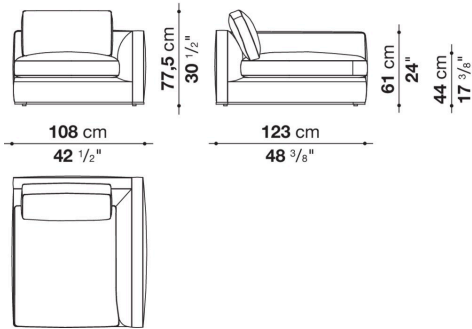

RA100C

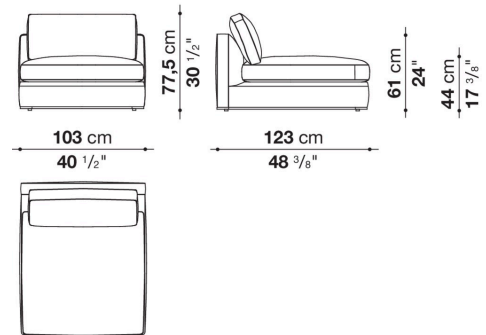

RA85P

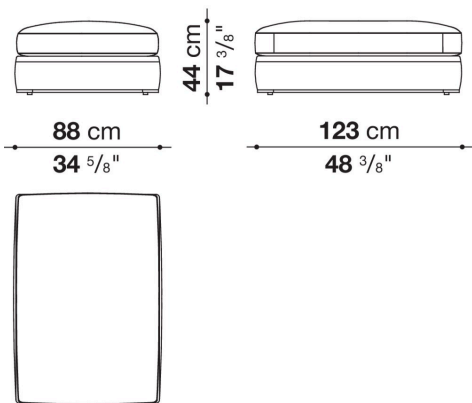

RA240P

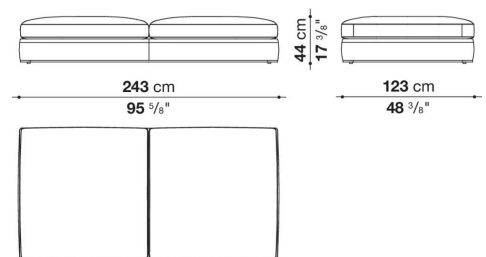

RA220P

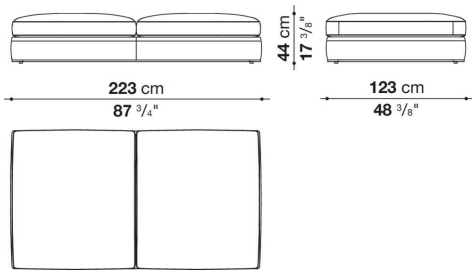

RA190P

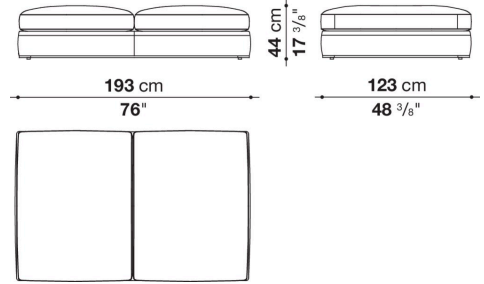

RA100P

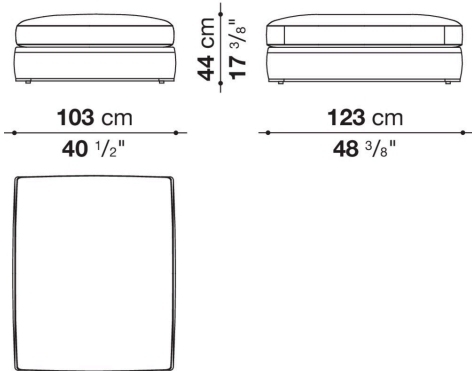

RA280

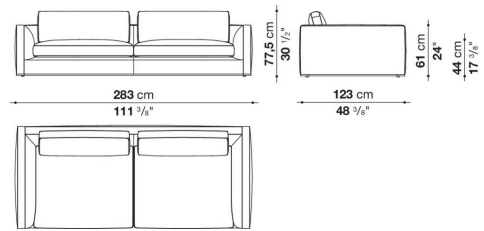

RA260

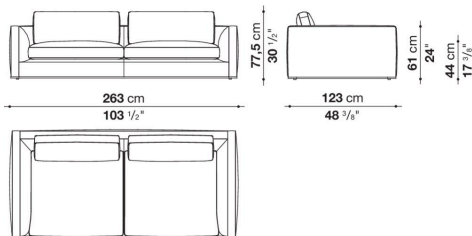

RA230

