

---

# B&B Atoll

SOFAS

2018

Antonio Citterio



---

## Description

B&B Atoll, das neue modulierbare Sofasystem von Antonio Citterio, dessen Name an die gleichnamigen Korallenriffe erinnert, ist Ausdruck einer ausgewogenen ästhetischen Form und eines entschiedenen modernen Stils von hoher Eleganz. Das System basiert auf drei Ausgangsplattformen in den Abmessungen 190 cm und 240 cm mit 90 cm Tiefe sowie 130 cm mit 140 cm Tiefe, die mit Arm- und Rückenlehnen auf verschiedene Weise kombiniert werden können: Rundsofas, Dormeusen, Eck-Endelemente, Einzelemente oder mit Chaiselongue und Hocker kombinierbare Elemente. Sie haben eine leichte und schlichte Linienführung und liegen auf hohen Trägern aus Aluminiumdruckguss mit Metallprofilen auf, die die Linie zwischen dem Gestell und der Polsterung unterstreichen, in den zwei Ausführungen Hartzinn und schwarz verchromt. Für zusätzliche Akzente sorgt ein Stützelement, das nach Belieben verwendet werden kann: ein Rollenkissen in zwei Größen (65 cm und 90 cm), das mit Lederriemen an einem Gestell aus Aluminiumdruckguss befestigt ist. Dieses Accessoire kann beliebig als zusätzliche Stütze zwischen das Sitzkissen und das Untergestell eingefügt werden oder je nach Wahl als Arm- bzw. Rückenlehne. B&B Atoll erweist sich somit als ein absolut dynamischer Entwurf, der immer wieder neu zu unzähligen Sofasystemen zusammengestellt werden kann: von informalen Relax Möbeln bis hin zu formalen Kombinationen, nicht zuletzt durch die Verwendung zusätzlicher Rückenkissen.

---

## Technical information

**Innenrahmen**

Stahlrohre und -profile

**Innenrahmen Füllung**

kalt elastischer Polyurethanschaum Bayfit®, Futter aus Polyesterfaser

**Sitzkissen**

geformtes Polyurethan verschiedener Dichten, sterilisierte Daunen, Futter aus Polyesterfaser

**Rückenkissen**

geformtes Polyurethan, sterilisierte Daunen

**Nierenkissen (AT45\_40)**

Daunen, Typ mit Umrandung

**Rollen**

geformtes Polyurethan, Futter aus Polyesterfaser

**Rollen-Träger**

Aludruckguss

**Rollen-Riemen**

Stoff oder Leder

**Traggestell**

Aludruckguss

**Gleiter**

Kunststoff

**Bezug**

Stoff oder Leder

# Technical drawings

**ATR247S\_3**

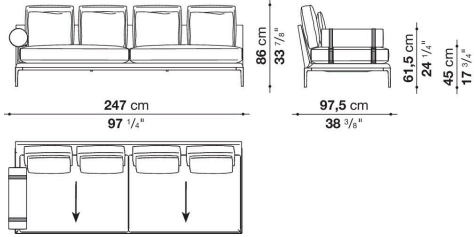

**ATR247S\_2**

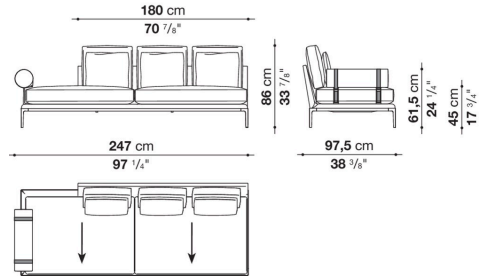

**ATR247S\_1**

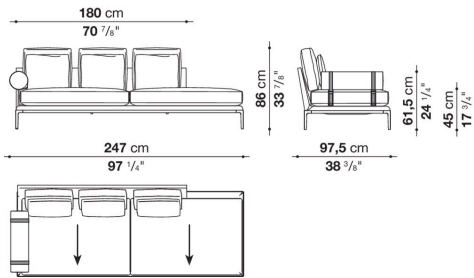

**ATR247D\_3**

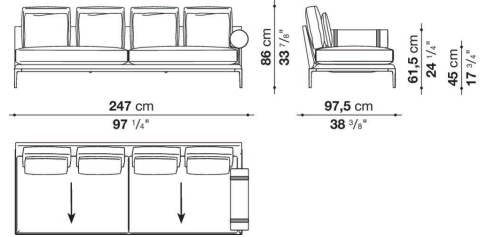

**ATR247D\_2**

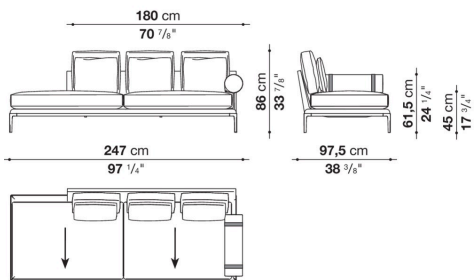

**ATR247D\_1**

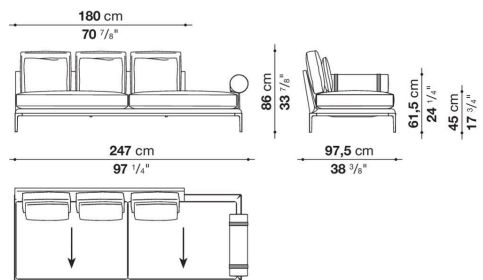

**ATR197S\_3**

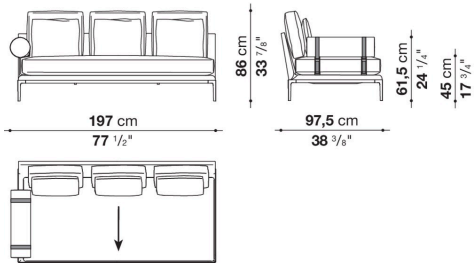

**ATR197S\_2**

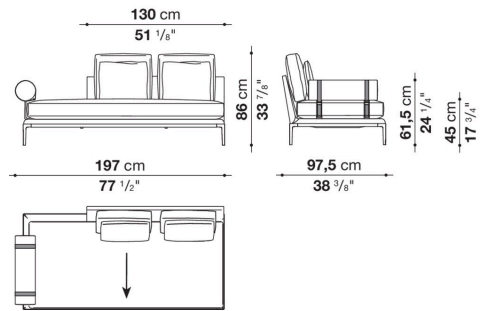

**ATR197S\_1**

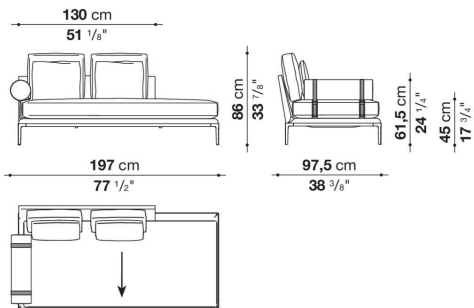

**ATR197D\_3**

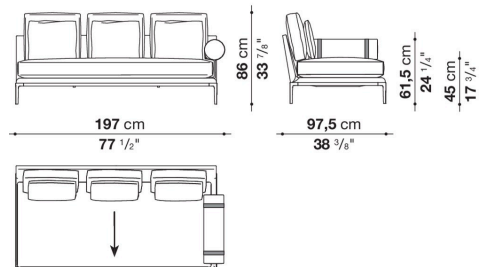

**ATR197D\_2**

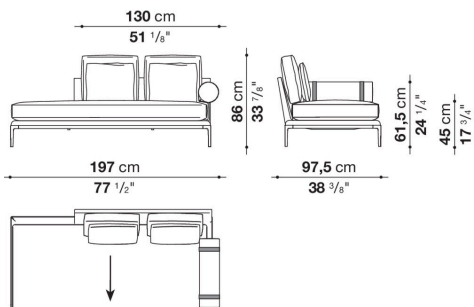

**ATR197D\_1**

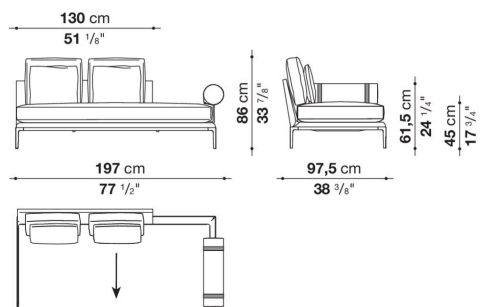

**ATR137LS**

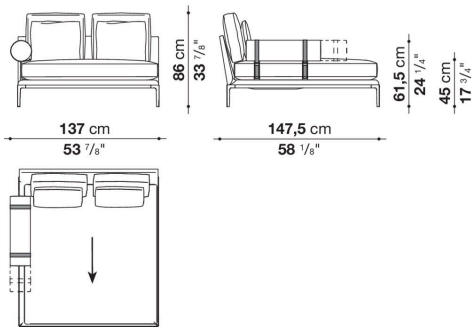

**ATR137LD**

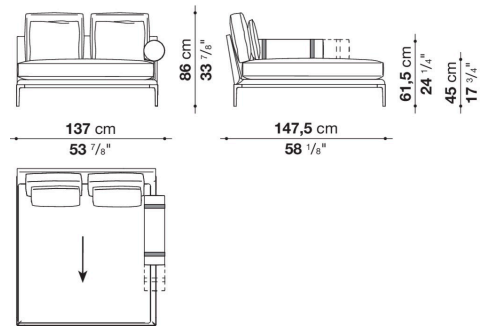

**AT248TAS\_3**

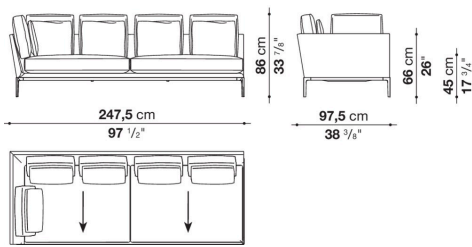

**AT248TAS\_2**

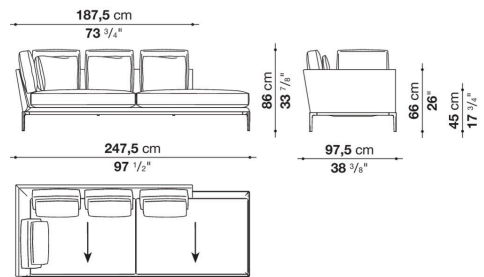

**AT248TAS\_1**

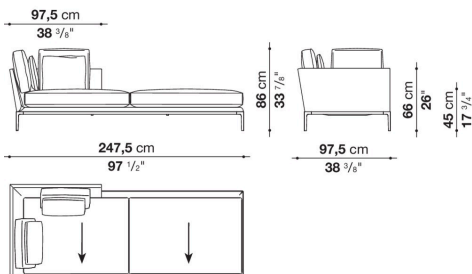

**AT248TAD\_3**

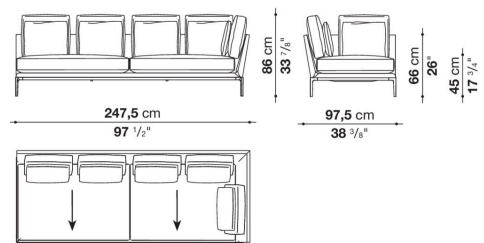

AT248TAD\_2

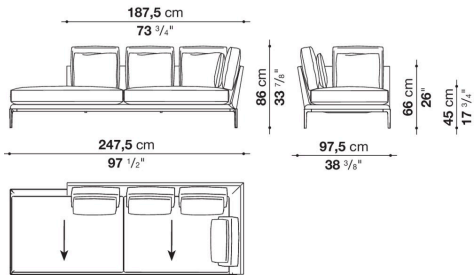

AT248S\_3

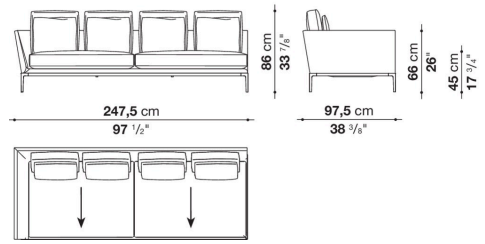

AT248TAD\_1

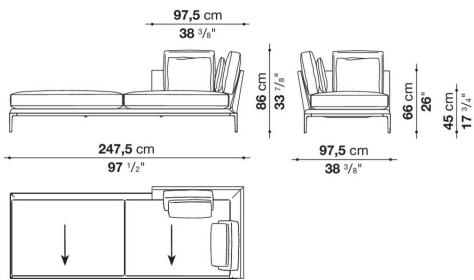

AT248S\_2

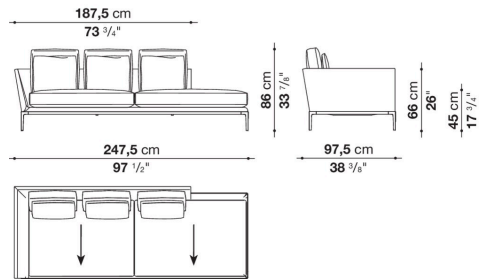

AT248S\_1

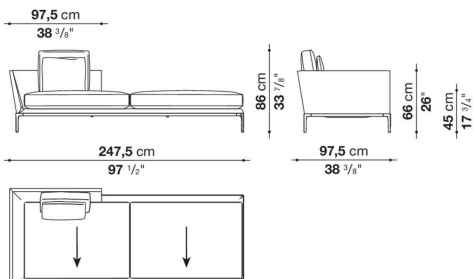

AT248LS\_2

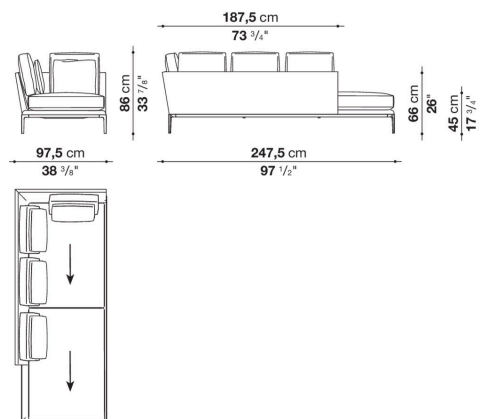

AT248LS\_1

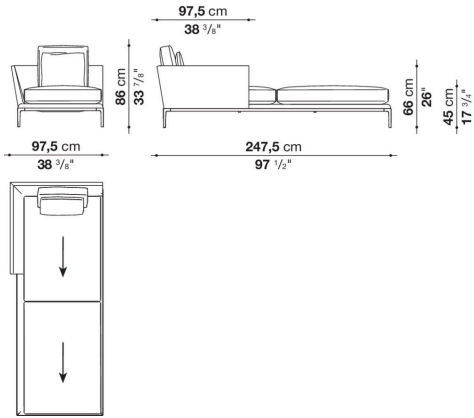

AT248LD\_2

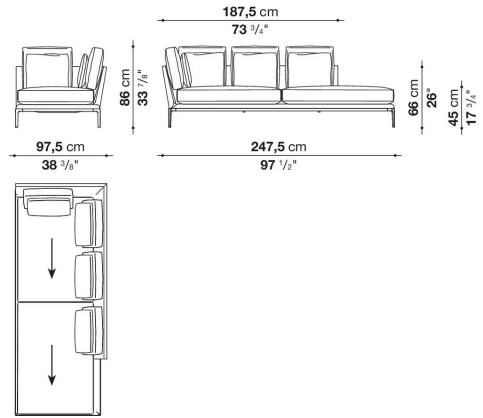

AT248LD\_1

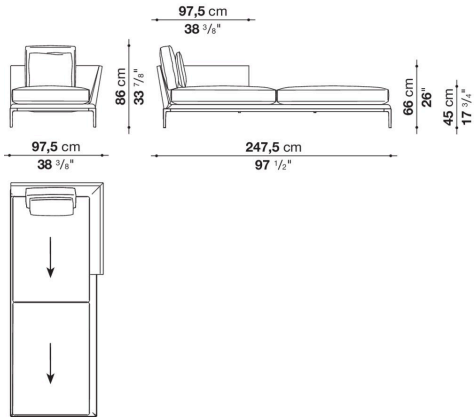

AT248D\_3

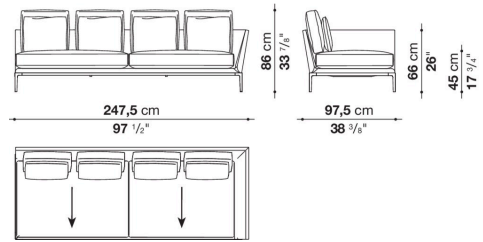

AT248D\_2

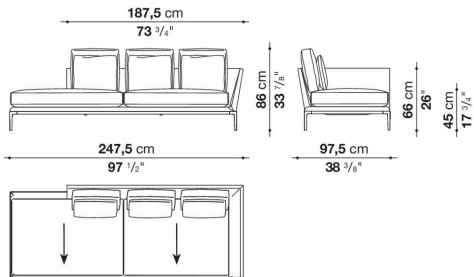

AT248D\_1

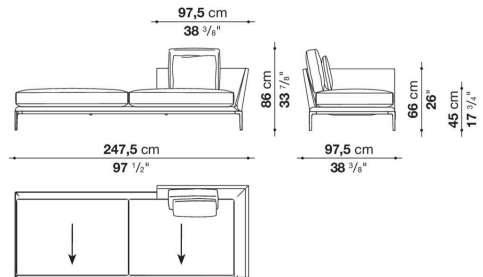

AT240PS

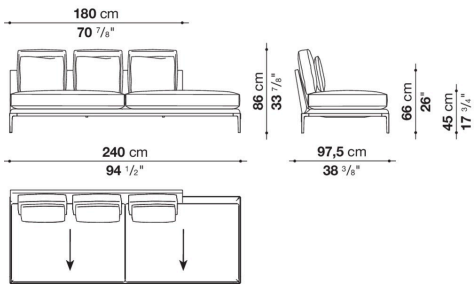

AT240PD

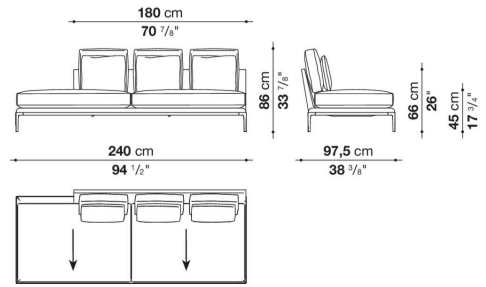

AT240C

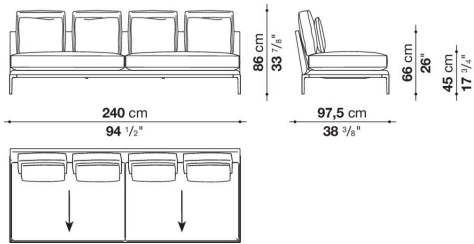

AT198TAS\_2

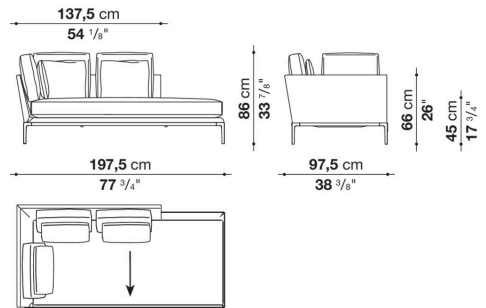

AT198TAS\_3

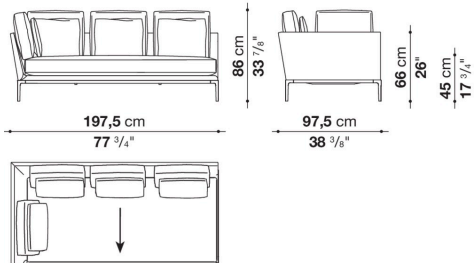

AT198TAS\_1

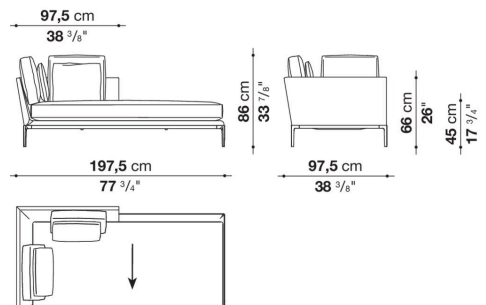



AT198TAD\_2

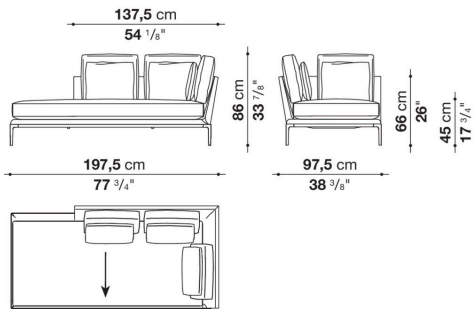

AT198TAD\_3

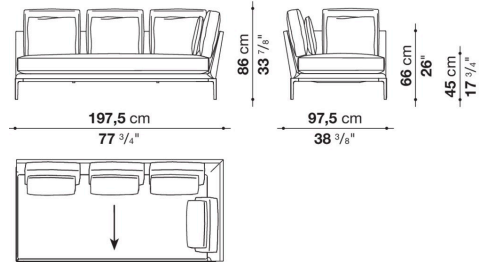

AT198TAD\_1

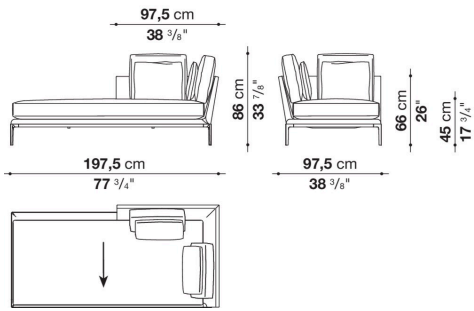

AT198S\_3

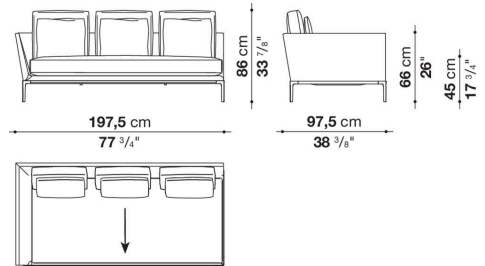

AT198S\_2

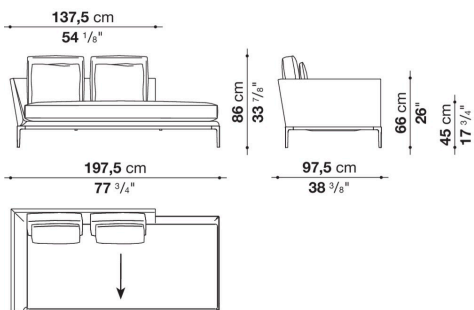

AT198S\_1

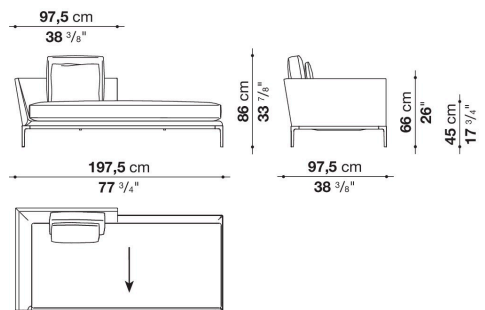

AT198LS\_2

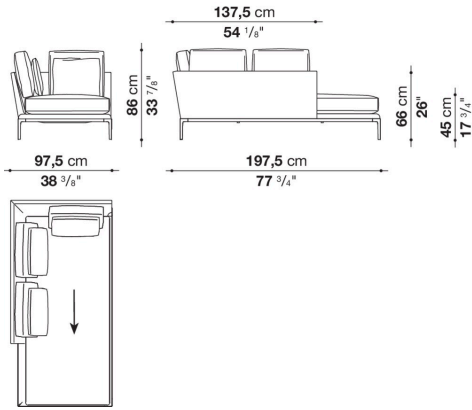

AT198LS\_1

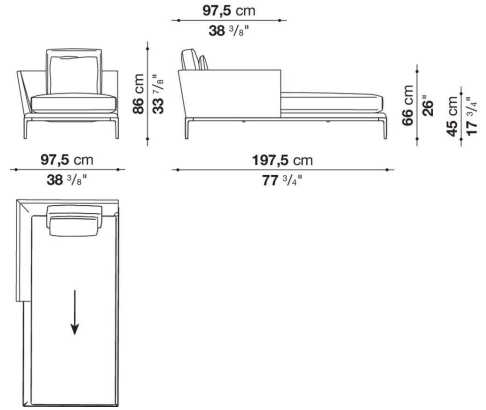

AT198LD\_2

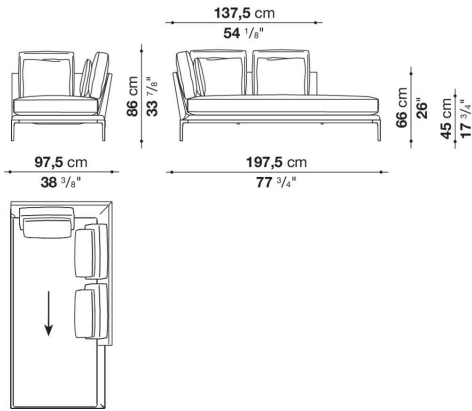

AT198LD\_1

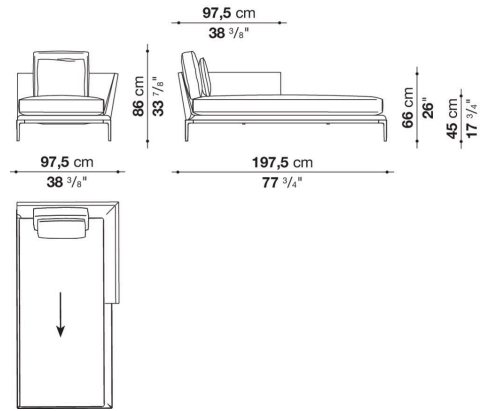

AT198D\_3

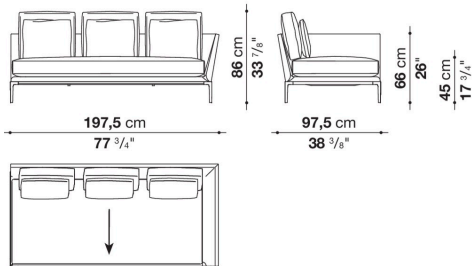

AT198D\_2

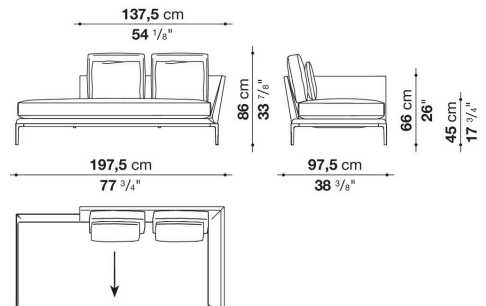

AT198D\_1

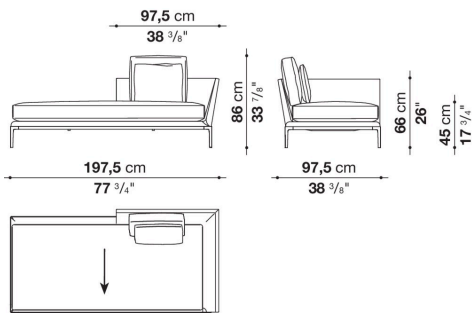

AT190C

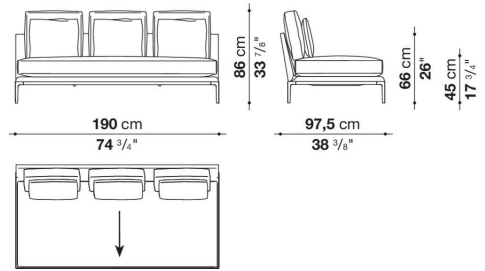

AT190PS

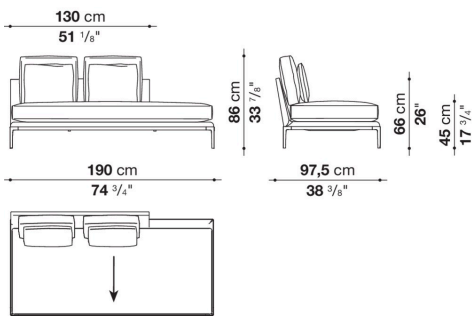

AT190PD

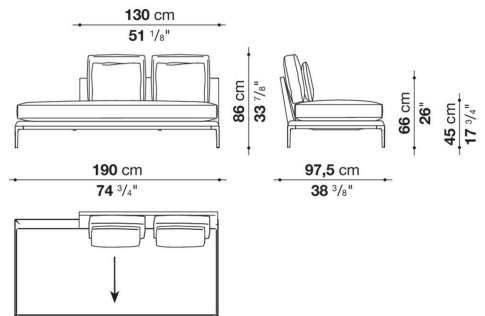

AT138LS

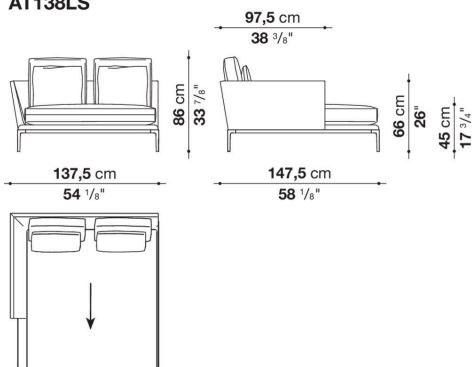

AT138LD

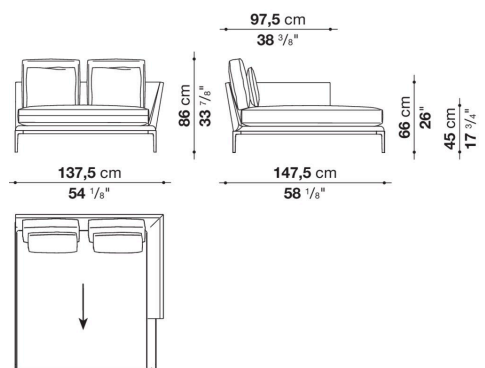

**AT130L**

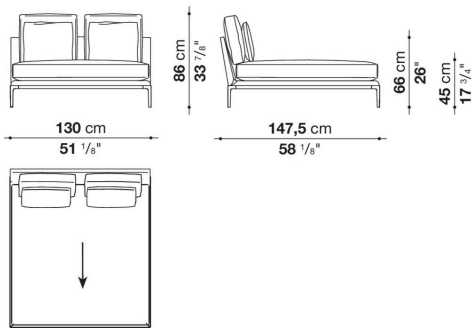

**ATR240P**

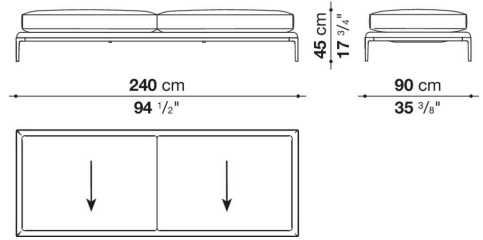

**ATR190P**

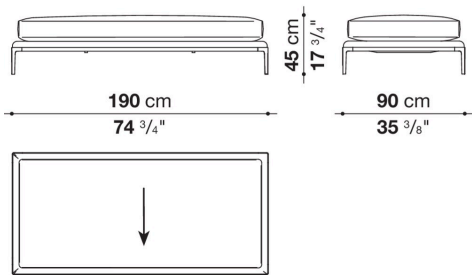

**ATR130PS**

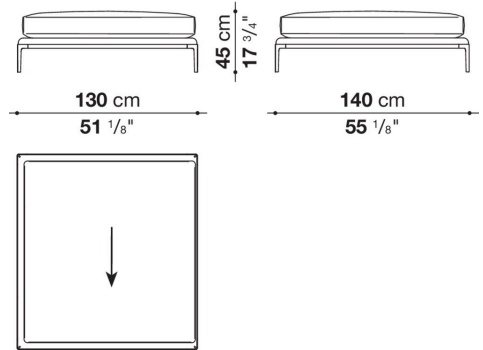

**ATR130PD**

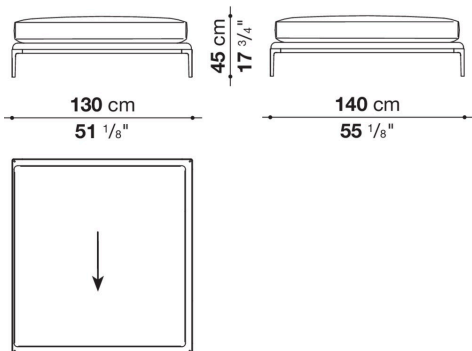

**ATR130P**

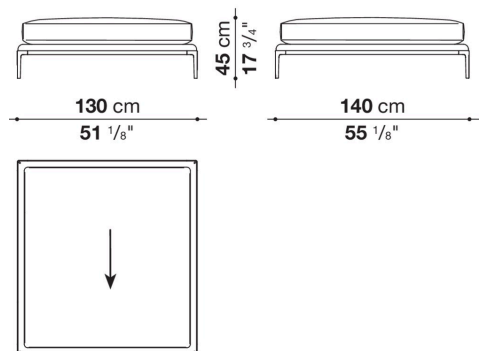

### AT89PQF

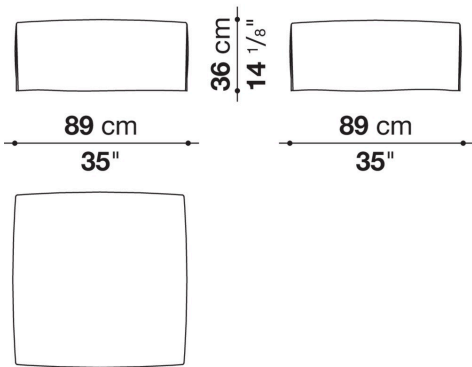

### AT154DPF

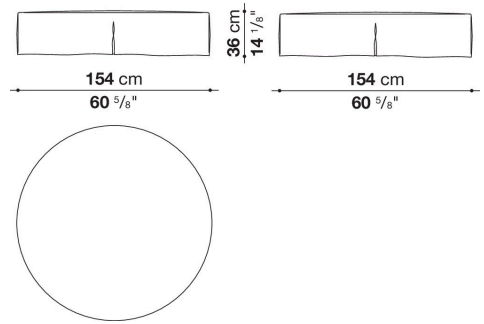

### AT153PQF

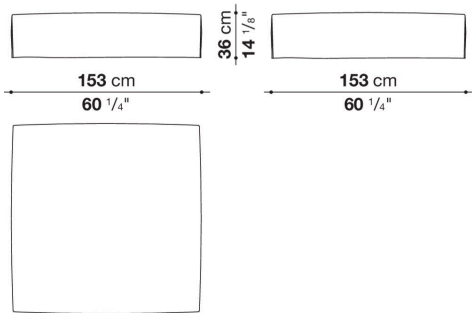

### AT153PF\_2

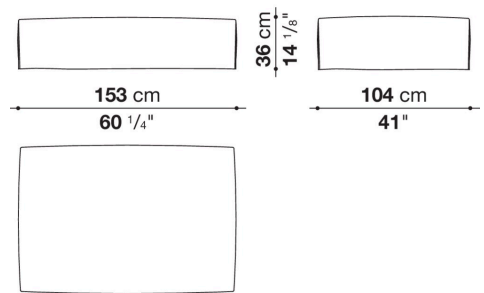

### AT153PF\_1

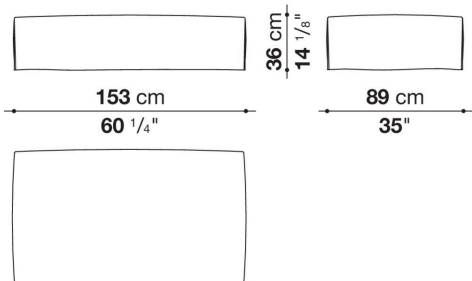

### AT110DPF

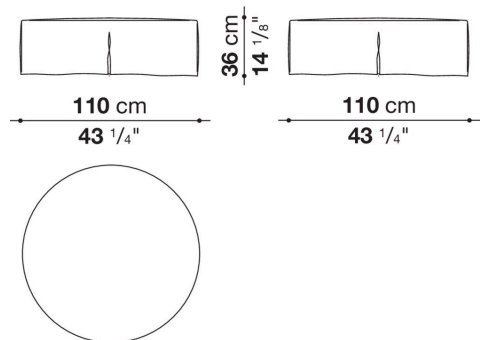

### AT104PQF

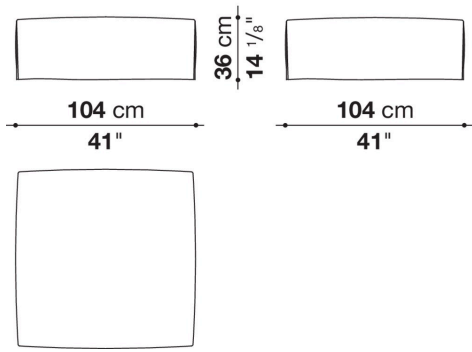

### ATR254

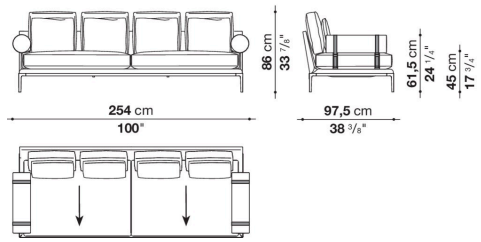

### ATR204

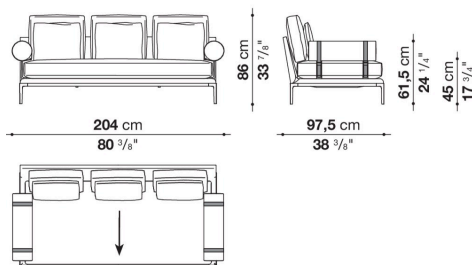

### AT255AS

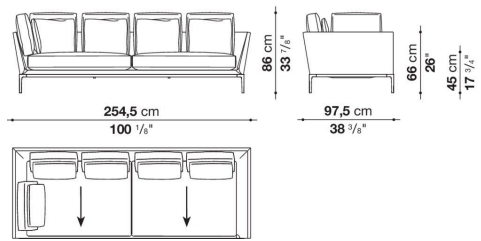

### AT255AD

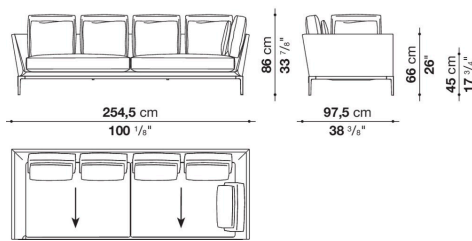

### AT255

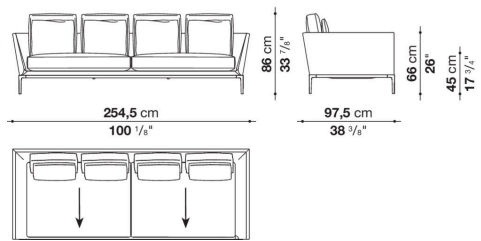

AT205AS

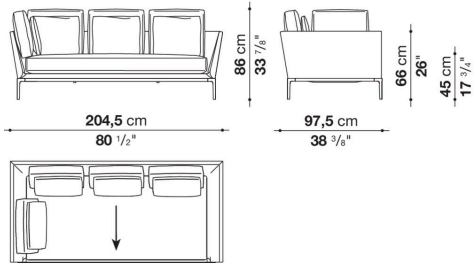

AT205AD

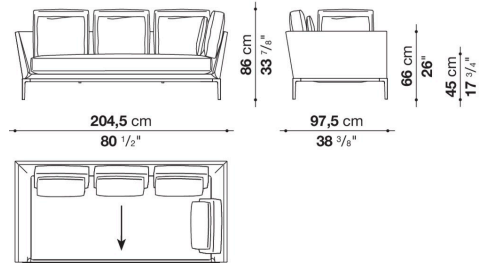

AT205

